

Příklad: Objekt - kosohlé promítání  $q=1/2$

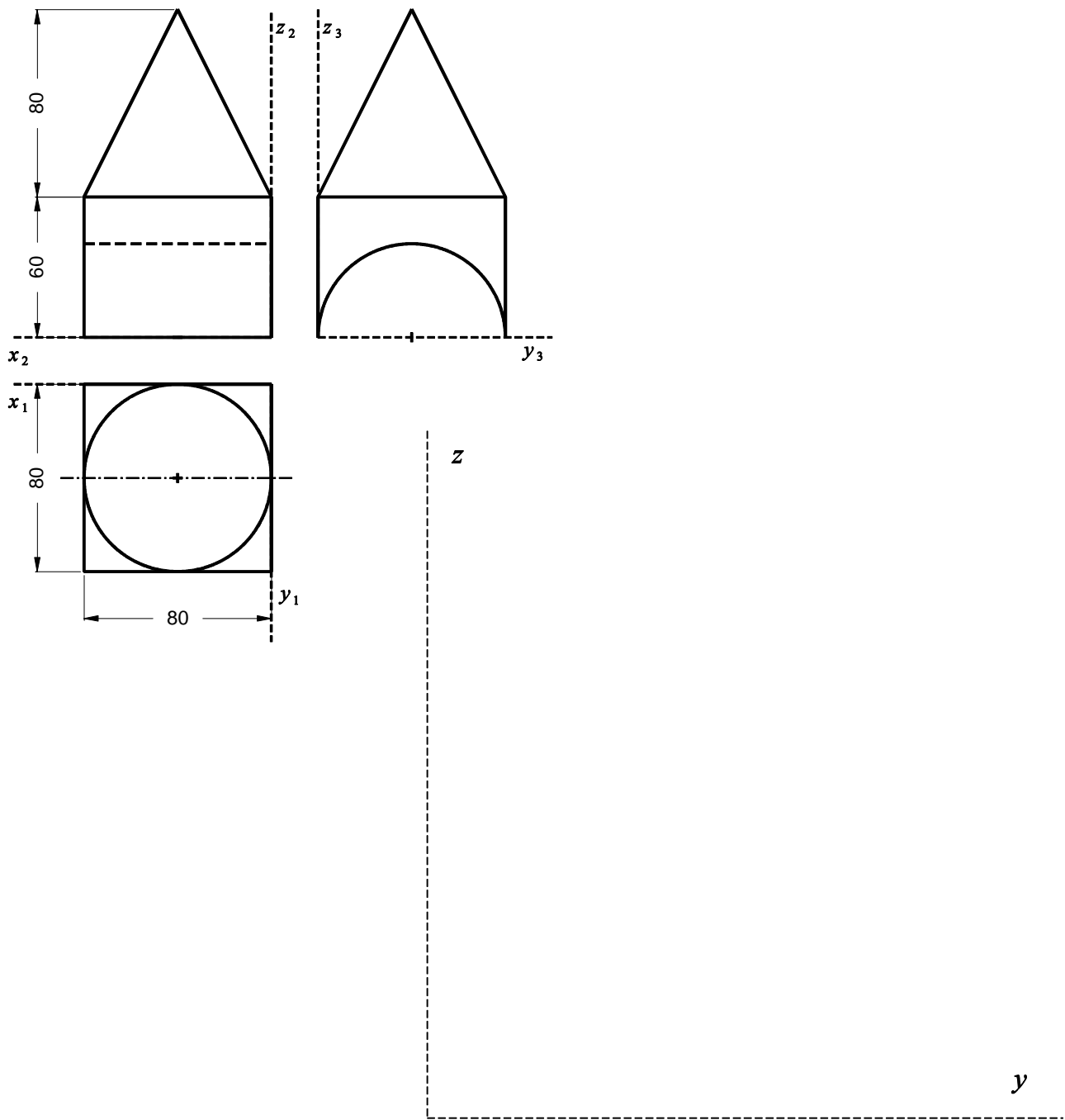

# Příklad: Objekt - technická isometrie

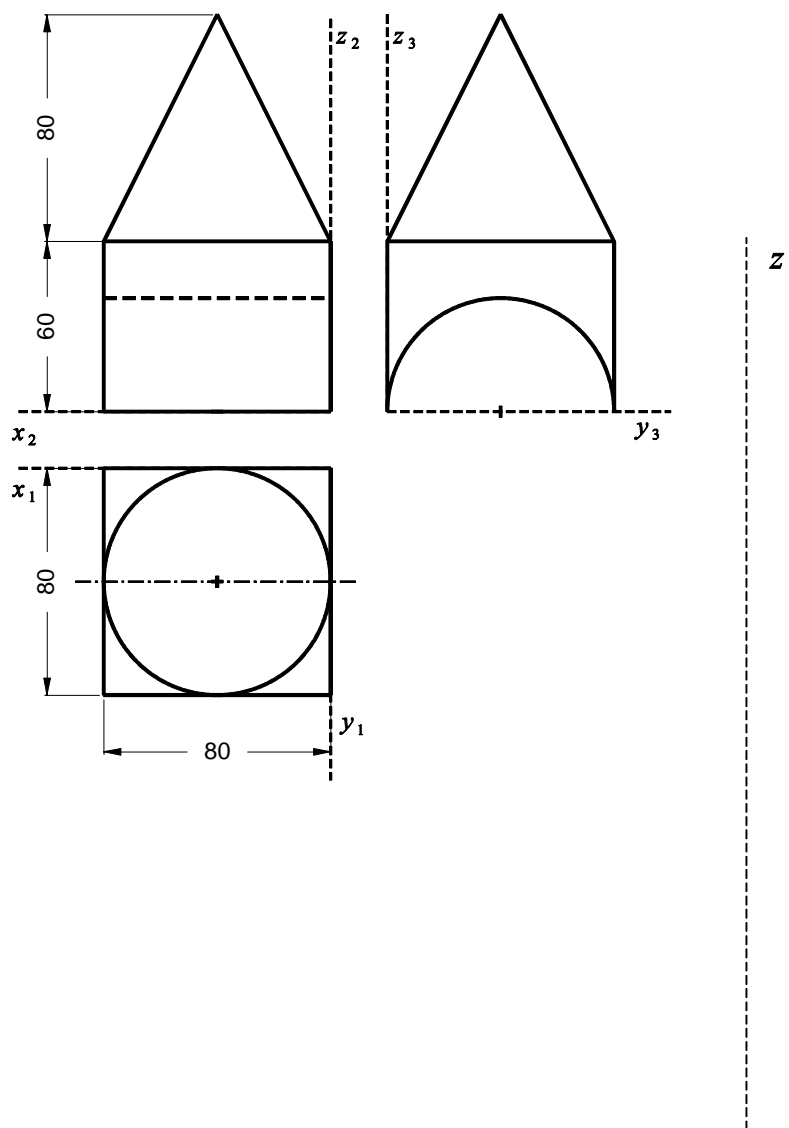

Příklad: Objekt 2 - technická isometrie

